



**BALTIMORE  
AIRCOIL COMPANY**



**S1500E Open Cooling Towers**  
**XES1500E Open Cooling Tower**

**RIGGING AND INSTALLATION INSTRUCTIONS**



# About rigging and installation

The BAC equipment should be rigged and installed as outlined in this bulletin.

These procedures should be thoroughly reviewed prior to the rigging and operation to acquaint all personnel with the procedures to be followed and to assure that all necessary equipment will be available at the job site. Be sure to have a copy of the unit certified drawing available for reference. If you do not have a copy of this drawing or if you need additional information about this unit, contact the local BAC representative. His name and phone number can be found on the [www.BaltimoreAircoil.com](http://www.BaltimoreAircoil.com). The model type and serial number of your equipment are indicated on the unit nameplate.

## Recommended maintenance and monitoring programme

Checks and adjustments	Start-Up	Weekly	Monthly	Quarterly	Every 6 months	Annually	Shutdown
Hot water basin	X			X			
Nozzles	X			X			
Cold water basin and basin strainers	X			X			
Operating level and make-up	X		X				
Blow down	X		X				
Sump heater package	X				X		
Belt tension	X		X				
Drive alignment	X					X	
Drive system	X				X		
Locking collar	X						
Rotation of fan(s) and pump (s)	X						
Motor voltage and current	X			X			
Unusual noise and/or vibration	X		X				

Inspections and monitoring	Start-Up	Weekly	Monthly	Quarterly	Every 6 months	Annually	Shutdown
General condition	X		X				
Heat transfer section and drift eliminators	X				X		
Double row drift eliminators (if applicable)	X				X		
Combined inlet shields	X			X			
Hot water basin	X			X			
Spray nozzles	X			X			
Fan shaft & Axial fan	X			X			
Fan motor	X			X			
Electric water level control package (option)	X				X		
Level or alarm switches				X			

Inspections and monitoring	Start-Up	Weekly	Monthly	Quarterly	Every 6 months	Annually	Shutdown
TAB test (dip slides)	X	X					
Circulating water quality	X		X				
System overview	X					X	
Record keeping	as per event						

Lubrication	Start-Up	Weekly	Monthly	Quarterly	Every 6 months	Annually	Shutdown
Fan shaft bearings	X			X			X
Motor bearings*	X				X		
Adjustable motor base	X				X		X
Hinges & access doors bolts						X	

\* only for motors with grease fittings with typical frame size > 200L (>30 kW)

Cleaning procedures	Start-Up	Weekly	Monthly	Quarterly	Every 6 months	Annually	Shutdown
Mechanical cleaning	X					X	X
Disinfection**	(X)					(X)	(X)
Drain basin							X

\*\* depends on applied code of practice

## Notes

1. Water treatment and auxiliary equipment integrated in the cooling system may require additions to the table above. Contact suppliers for recommended actions and their required frequency.
2. Recommended service intervals are for typical installations. Different environmental conditions may dictate more frequent servicing.
3. When operating in ambient temperatures below freezing, the unit should be inspected more frequently (see Cold weather operations in the appropriate Operating and Maintenance Instructions).
4. For units with belt drive, tension on new belts must be readjusted after the first 24 hours of operation and monthly thereafter.



# Table of contents

## RIGGING AND INSTALLATION INSTRUCTIONS

<b>3</b>	<b>General information</b>	<b>5</b>
	About engineering and application practices	5
	Shipping	5
	Inspection before rigging	5
	Unit weights	6
	Anchoring	7
	Leveling	7
	Electrical connections	7
	Connecting pipework	7
	Freeze protection	7
	Bleed Line Installation	8
	Safety Precautions	8
	Non-walking surfaces	9
	Modifications by others	9
	Warranty	10
<b>4</b>	<b>Rigging</b>	<b>11</b>
	General Notes	11
	Rigging information	11
	Rigging method for upper section & fully assembled unit	13
	Rigging method for lower section	13
	Rigging method for single piece lift	14
<b>5</b>	<b>Section Assembly</b>	<b>16</b>
	Method for two-piece cells	16
	Shipped loose fan cowl (if applicable)	18
<b>6</b>	<b>Optional Accessories Assembly</b>	<b>19</b>
	General	19
	Clean out port	20
<b>7</b>	<b>Inspection prior to start-up</b>	<b>21</b>
	General	21
<b>8</b>	<b>Further Assistance &amp; Information</b>	<b>22</b>
	The service expert for BAC equipment	22
	More information	22

## About engineering and application practices

This bulletin only refers to the assembly of the unit. To ensure a proper operation, a correct integration of the unit in the overall installation is mandatory. For good engineering and application practices on layout, levelling, connecting pipework, etc., please refer to our website:  
<http://www.baltimoreaircoil.eu/knowledge-center/application-information>.

## Shipping

BAC cooling equipment is factory assembled to assure uniform quality and minimum field assembly. The models S15E/XES15E-0809-06x, S15E/XES15E-0812-06x, S15E/XES15E-1012-06x, S15E/XES15E-1212-07x and S15E/XES15E-1218-07x are shipped in one single section. All other S15E models are shipped in two sections (upper and lower) due to shipping height restrictions. For the dimensions and weights of a specific unit or section, refer to the certified drawing.



### CAUTION

**Do not cover units with PVC eliminators or fill with a plastic tarpaulin. Temperature increase due to sun radiation could deform the fill or eliminators.**

## Inspection before rigging

When the unit is delivered to the job site, it should be checked thoroughly to ensure all required items have been received and are free of any shipping damage prior to signing the bill of lading.

The following parts should be inspected:

- Sheaves and belts
- Bearings
- Bearing supports
- Fan motor(s)
- Fan guards
- Fan(s) and fan shaft(s)
- Wet deck surface with integral drift eliminators
- Water distribution system
- Strainers
- Float valve assembly
- Combined inlet shields
- Interior / exterior surfaces
- Mating surfaces between sections / modules

- Miscellaneous items

An envelope with check-list is stored in a wooden no nail crate or a plastic container which is placed in the lower section. For safety reasons, access doors / panels may be sealed with bolts. The following table specifies which wrench is required to open them.

Wrench to open access door
17 mm

*Required wrenches to open access door*

The wooden no nail crate / plastic container also contains miscellaneous parts such as gasket, hardware and accessory items.

At temperatures below -10°C the butyl sealer tape might loose it's flexibility. We recommend to store the sealer tape in a heated room before using it during rigging at freezing temperatures.



**CAUTION**

**Be sure to remove all miscellaneous items from the pan before the unit is assembled.**

The hardware is packed in a plastic container and located inside the lower section of the unit. The plastic container is fixed with straps to the internal walkway.

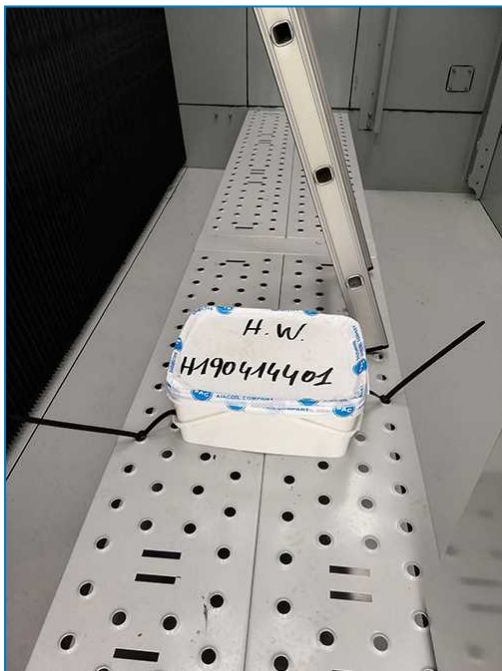

*Hardware Location*

## Unit weights

Before rigging any BAC equipment, the weight of each section should be verified on the unit certified drawing.



These weights are **approximate** and should be confirmed by weighing **before lifting** when available hoisting capacity provides little margin for safety.



#### CAUTION

**Before an actual lift is undertaken, ensure no water, snow, ice or debris has collected in the sump or elsewhere in or on the unit. Such accumulations will add substantially to the equipment's lifting weight.**

In the event of extended lifts or where hazards exist, the lifting devices should be used in conjunction with safety slings placed under the unit.

## Anchoring

The unit must be properly anchored in place.

Refer to the suggested support details on the certified drawing for locations of the mounting holes. Anchor bolts must be provided by others.

Holes suitable for 20 mm bolts are provided in the bottom flange of the lower section for bolting the unit to the support beams.

## Leveling

The unit must be level for proper operation and ease of piping.

## Electrical connections

The units are delivered with a number of electrical components that need to be connected after rigging. For all electrical components, please refer to the specific wiring diagrams in the submittal package.

## Connecting pipework

All piping external to BAC cooling equipment must be supported separately.

In case the equipment is installed on vibration rails or springs, the piping must contain compensators to eliminate vibrations carried through the external pipework.

The equipment outlet piping must be installed under the operating level of the equipment to prevent air suction and pump cavitation.

Suction pipe sizing should be done according to good practice, which may for larger flows require larger pipe diameters than the outlet connection. In such cases adapter pieces need to be installed.

## Freeze protection

These products must be protected against damage and/or reduced effectiveness due to possible freeze-up by mechanical and operational methods. Please contact your local BAC representative for recommended protection alternatives.



## Bleed Line Installation

On all open cooling towers, install a bleed line with valve between the system circulating pump discharge riser and a convenient drain. Locate the bleed line in a portion of the riser piping that drains when the pump is off. The bleed valve should always be open when the unit is in operation, unless the bleed rate is automatically controlled by a water treatment system.

## Safety Precautions

All electrical, mechanical and rotating machinery constitutes a potential hazard, particularly for those not familiar with its design, construction and operation. Accordingly, adequate safeguards (including use of protective enclosures where necessary) should be taken with this equipment both to safeguard the public (including minors) from injury and to prevent damage to the equipment, its associated system and the premises.

If there is doubt about safe and proper rigging, installation, operation or maintenance procedures, contact the equipment manufacturer or his representative for advice.

When working on operating equipment, be aware that some parts may have an elevated temperature. Any operations on elevated level have to be executed with extra care to prevent accidents.

### AUTHORIZED PERSONNEL

The operation, maintenance and repair of this equipment should be undertaken only by personnel authorized and qualified to do so. All such personnel should be thoroughly familiar with the equipment, the associated systems and controls and the procedures set forth in this and other relevant manuals. Proper care, personal protective equipment, procedures and tools must be used in handling, lifting, installing, operating, maintaining and repairing this equipment to prevent personal injury and/or property damage. Personnel must use personal protective equipment where necessary (gloves, ear plugs, etc...)

### MECHANICAL SAFETY

Mechanical safety of the equipment is in accordance with the requirements of the EU machinery directive. Depending upon site conditions it also may be necessary to install items such as bottom screens, ladders, safety cages, stairways, access platforms, handrails and toe boards for the safety and convenience of the authorized service and maintenance personnel.

At no time this equipment should be operated without all fan screens, access panels and access doors in place/closed and properly secured.

When the equipment is operated with a variable fan speed control device, steps must be taken to avoid operating at or near to the fan's «critical speed».

For more information consult your local BAC representative.

### ELECTRICAL SAFETY

All electrical components associated with this equipment should be installed with a lockable disconnect switch located within sight of the equipment.

In the event of multiple components, these can be installed after a single disconnect switch but multiple switches or a combination thereof are also allowed.

No service work should be performed on or near electrical components unless adequate safety measures are taken. These include, but are not limited to the following:

- Isolate the component electrically
- Lock the isolation switch in order to prevent unintentional restart
- Measure that no electrical voltage is present any more
- If parts of the installation remain energized, make sure to properly demarcate these in order to avoid confusion

Fan motor terminals and connections may have residual voltage after unit shut-down. Wait five minutes after disconnecting the voltage at all poles before opening the fan motor terminal box.



## LIFTING



### CAUTION

**Failure to use designated lifting points can result in a dropped load causing severe injury, death and/or property damage. Lifts must be performed by qualified riggers following BAC published Rigging Instructions and generally accepted lifting practices. The use of supplemental safety slings may also be required if the lift circumstances warrant its use, as determined by the rigging contractor.**

## LOCATION

All cooling equipment should be located as far away as possible from occupied areas, open windows or air intakes to buildings.



### CAUTION

**Each unit should be located and positioned to prevent the introduction of discharge air into the ventilation systems of the building on which the unit is located or those of adjacent buildings.**



For detailed recommendations on BAC equipment layout, please see the BAC Application Handbook EU-Edition, the BAC website: [www.baltimoreaircoil.eu](http://www.baltimoreaircoil.eu) or contact your local BAC Representative.

## LOCAL REGULATIONS

Installation and operation of cooling equipment may be subject to local regulations, such as establishment of risk analysis. Ensure regulatory requirements are consistently met.

## Non-walking surfaces

Access to and maintenance of any component needs to be performed in accordance with all local applicable laws and regulations. If the proper and required access means are not present, temporary structures need to be foreseen. Under no circumstance can one use parts of the unit, that are not designed as an access mean, unless measures can be taken to mitigate any risks that might occur from doing so.

## Modifications by others

Whenever modifications or changes are made by others to the BAC equipment without written permission of BAC, the party who has done the modification becomes responsible for all consequences of this change and BAC declines all liability for the product.



## Warranty

BAC will guarantee all products to be free from manufactured defects in materials and workmanship for a period of 24 months from the date of shipment. In the event of any such defect, BAC will repair or provide a replacement. For more details, please refer to the Limitation of Warranties applicable to and in effect at the time of the sale/purchase of these products. You can find these terms and conditions on the reverse side of your order acknowledgement form and your invoice.

# 4

## S1500E XES1500E RIGGING

### General Notes

1. Units that ship in multiple sections can be assembled on the ground first before being lifted to their final position. (see "Single piece lift" in the following table).
2. Spreader bars of the full width of the section must be used between the lifting cables to prevent damage to the section.
3. For extended lifts or where hazards exist, it is recommended to use the lifting devices in conjunction with safety slings placed under the unit.

When the unit is installed, all metal parts created by drilling, fastening self tapping screws, grinding, welding or other mechanical works must be removed from the unit. If they remain on the unit (typically on the double break flanges) this could lead to corrosion and eventually coating damage. .

4. The proper rigging sequence for units is to lift the lower section into place, apply sealer to the pan where the upper section will be located (See "Section Assembly""Method for two-piece cells" on page 16) and then lift the upper section into place.
5. Lifting devices have been provided on all sections. The tables below give the preferred method for rigging each section of a unit.

### Rigging information



*Unit sections*

1. Upper section
2. Lower section

#### *Rigging method*



Model number	N° of lower sections	N° of upper sections	Upper section				Lower section				Single piece lift			
			Rigging method	W1 (mm)	W2 (mm)	Min. "H" (mm)	Rigging method	W1 (mm)	W2 (mm)	Min. "H" (mm)	Rigging method	W1 (mm)	W2 (mm)	Min. "H" (mm)
S15E/XES15E-0809-06x	FULLY ASSEMBLED		-	-	-	-	-	-	-	-	A	2400	1200	3400
S15E/XES15E-0812-06x	FULLY ASSEMBLED		-	-	-	-	-	-	-	-	A	2400	1200	3400
S15E/XES15E-1012-06x	FULLY ASSEMBLED		-	-	-	-	-	-	-	-	A	3000	1500	3400
S15E/XES15E-1012-09x	1	1	A	3000	1350	2700	B	3000	1500	2100	C	3000	1500	4600
S15E/XES15E-1012-10x	1	1	A	3000	1350	2700	B	3000	1500	2400	C	3000	1500	4900
S15E/XES15E-1018-09x	1	1	A	3000	1350	2700	B	3000	1500	2100	C	3000	1500	4600
S15E/XES15E-1018-10x	1	1	A	3000	1350	2700	B	3000	1500	2700	C	3000	1500	5200
S15E/XES15E-1212-07x	FULLY ASSEMBLED				-	-	-	-	-	-	A	3600	1800	3700
S15E/XES15E-1212-09x	1	1	A	3600	1800	2700	B	3600	1700	2100	C	3600	1800	4600
S15E/XES15E-1212-10x	1	1	A	3600	1800	2700	B	3600	1700	2400	C	3600	1800	4900
S15E/XES15E-1212-11x	1	1	A	3600	1800	2700	B	3600	1700	2700	C	3600	1800	5200
S15E/XES15E-1212-12x	1	1	A	3600	1800	2700	B	3600	1700	3400	C	3600	1800	5800
S15E/XES15E-1218-07x	FULLY ASSEMBLED				-	-	-	-	-	-	A	3600	1800	1800
S15E/XES15E-1218-09x	1	1	A	3600	1800	2700	B	3600	1700	2100	C	3600	1800	4600
S15E/XES15E-1218-10x	1	1	A	3600	1800	2700	B	3600	1700	2700	C	3600	1800	5200
S15E/XES15E-1218-11x	1	1	A	3600	1800	2700	B	3600	1700	3000	C	3600	1800	5500
S15E/XES15E-1218-12x	1	1	A	3600	1800	2700	B	3600	1700	3400	C	3600	1800	5800

*Rigging method*

# Rigging method for upper section & fully assembled unit



## RIGGING METHOD A

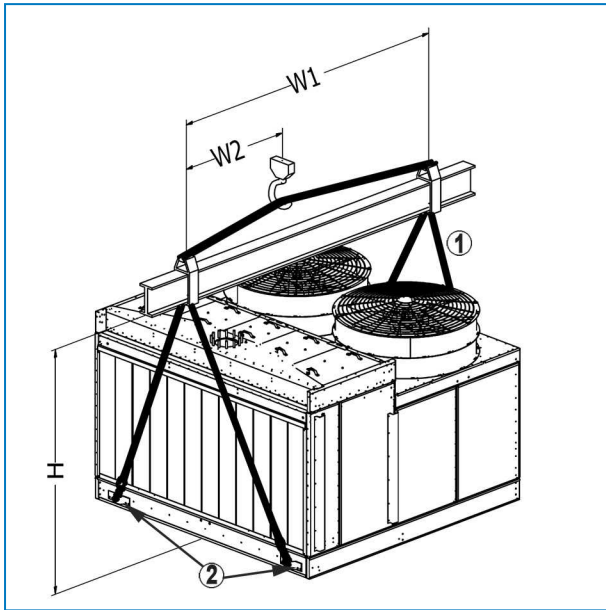

- 1. Lifting cable
- 2. Lifting ears

## Rigging method for lower section

### RIGGING METHOD B

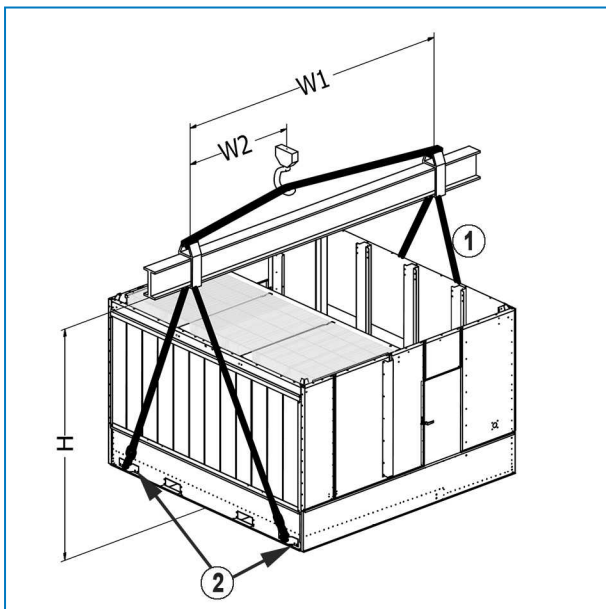

- 1. Lifting cable
- 2. Lifting ears



**CAUTION**

Do not use tie down buckle for lifting and lifting ears for tie down purpose.

## Rigging method for single piece lift

### RIGGING METHOD C

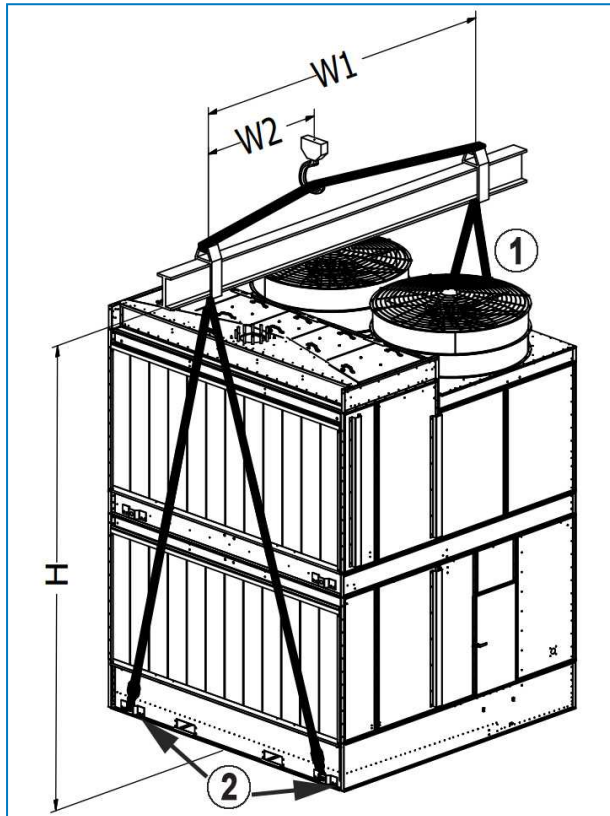

- 1. Lifting cable
- 2. Lifting ears



Pay attention to the difference in lifting ear and tie down buckle on the lower section.

For units boxsize 08x09, 08x12, 10x12, 12x12 pay attention to the difference in lifting ear and tie down buckle on the fan side of the unit (opposite to air intake).

The **lifting ear** is to be used to unload unit from truck. It is designed for **upward** force.

The **tie-down buckle** is only to be used to tie down (secure) unit onto truck for transport. It is designed for **downward** force only.

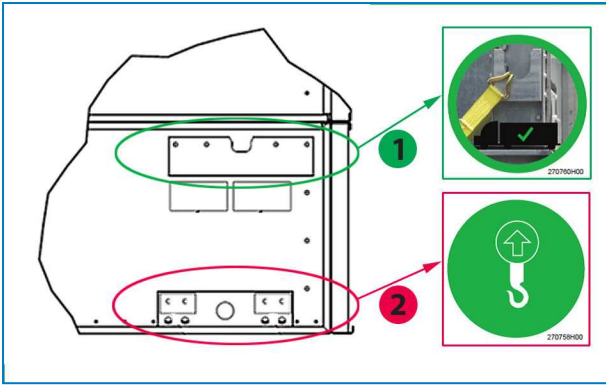

*Position tie down buckle and lifting ear on lower section*

1. Proper use of tie down buckle is shown on logo
2. Proper use of lifting ear is shown on logo

# S1500E XES1500E SECTION ASSEMBLY

## Method for two-piece cells

1. Position the lower section on the supporting steel and bolt in place.
2. Remove any protective wood from the top horizontal flanges of the lower section. Wipe down the flanges to remove dust, dirt or moisture that may have accumulated during shipment and storage.
3. Install butyl sealer tape, supplied with the unit, on the mating flanges of the lower section in a continuous line over the centre line of the taper holes. At each corner, allow 2 to 3 cm overlap. Do not stretch sealer tape.
4. Sealer applied to the end flanges of a single cell section unit and to the end and centre flanges of two cell units must be continuous.

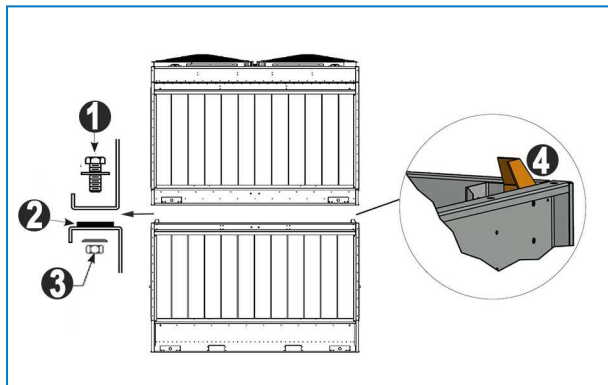

*Installation of tape sealer*

1. Bolt M10
2. Flat tape sealer laid over punch line around unit perimeter
3. Flatwasher, lockwasher and nut
4. Section assembly guide

5. Remove the skid from the middle section. Lift the middle section and position it over the lower section so that the flanges of the section are about 50 mm above the lower section. Do not let the section swing and damage the sealer.

Use at least four drift pins (see figure) in the fastening holes located on the long sides of the sections to align the top section to the bottom section. To avoid incorrect alignment, refer to the below drawing for the position of the fastening holes to be used. Use additional drift pins in the middle of the unit if required, to align long panels. (See figure "Usage of drift pin to align the screw holes")

Make sure all holes from upper section and lower section are properly aligned before lowering the top section completely to the bottom section.



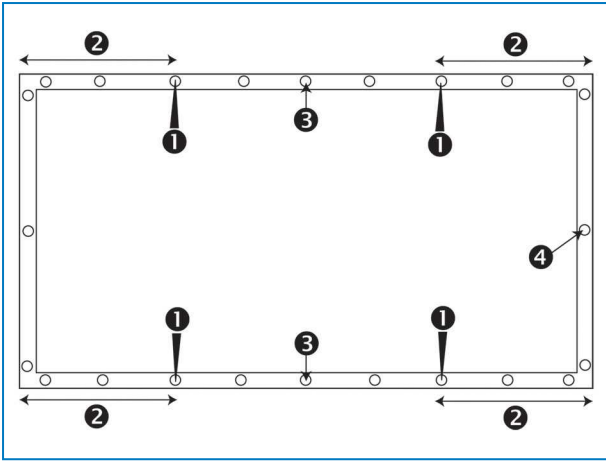

*Position of the fastening holes to be used.*

1. Drift pin position
2. The distance between the fastening hole in which the drift pin is inserted and the corner should be at least 30cm
3. Usage of additional drift pin for long sides
4. Fastening hole



**CAUTION**

**When lowering a section, ensure nothing can be trapped between the upper and lower flanges.**

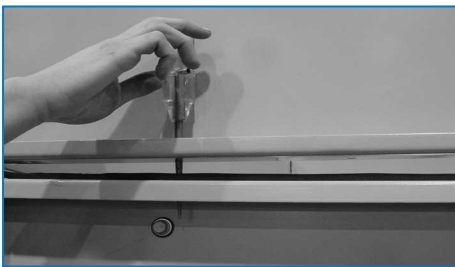

*Usage of drift pin to align the screw holes*

6. Using the bolts, drive bolts down through the upper section and into the lower section. Start next to lifting ear towards centre of unit. Continue to install the bolts using the drift pin to align the holes until all holes are filled with bolts.



## Shipped loose fan cowl (if applicable)

1. Lift a single fan cowl with fan guard onto the factory installed fan cowls.

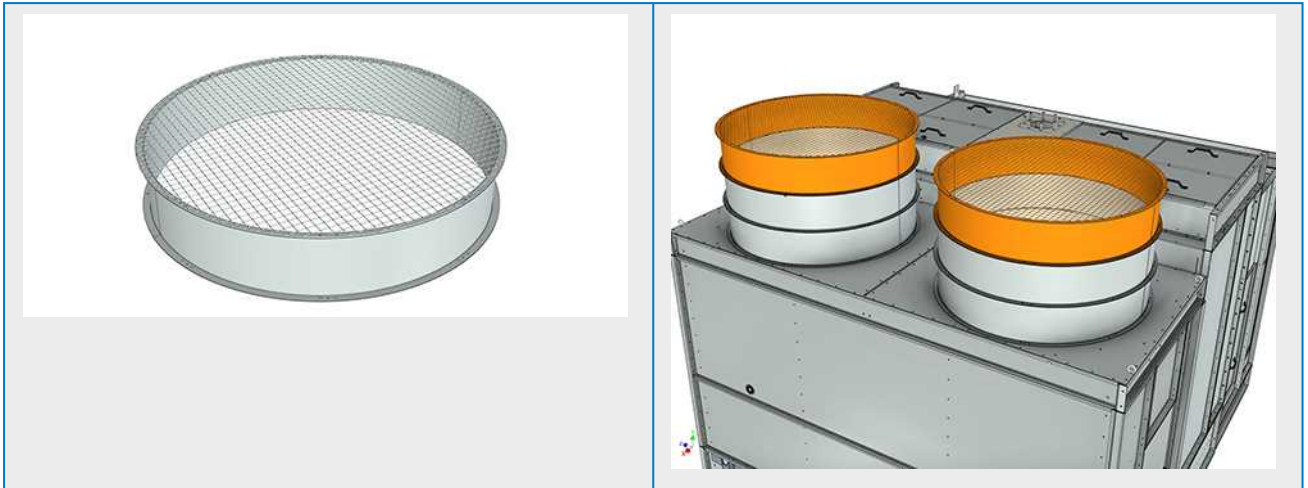

2. Align the hole pattern (use drift pins if required) and tighten with bolts and nuts.



# 6

S1500E

XES1500E

## OPTIONAL ACCESSORIES ASSEMBLY

### General

1. All required installation instructions for optional accessories are stored in the wooden no nail crate / plastic container which is placed in the lower section. See "Inspection Before Rigging" on page 1 - picture "Hardware Location".
2. Refer to the unit certified drawing for installation sequence of optional accessories.
3. Sealing methods are the same as for the upper section.
4. The platform, ladder and railing is packed on a separate skid. The assembly hardware is packed in a plastic container and strapped to the platform, ladder or railing itself.



*Hardware location for platform, ladder & railing*

## Clean out port

Due to transport width limits, the cover flanges of the clean out port are mounted with flanges towards the inside (1). On site, the cover can be placed with flanges to the outside for easy access to hardware (2).

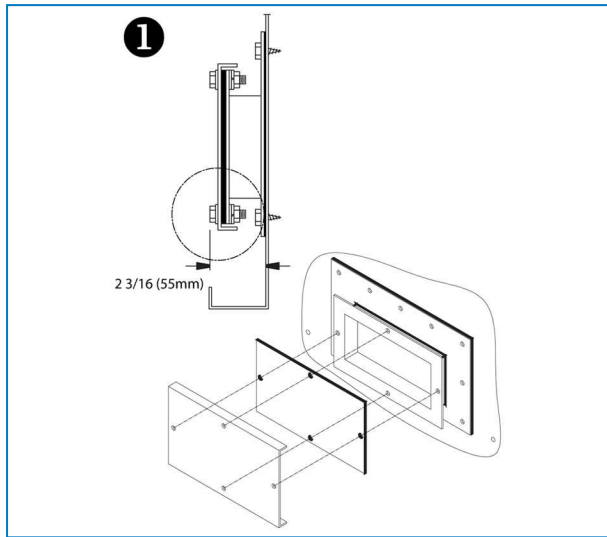

*Clean out port cover mounted for transport*

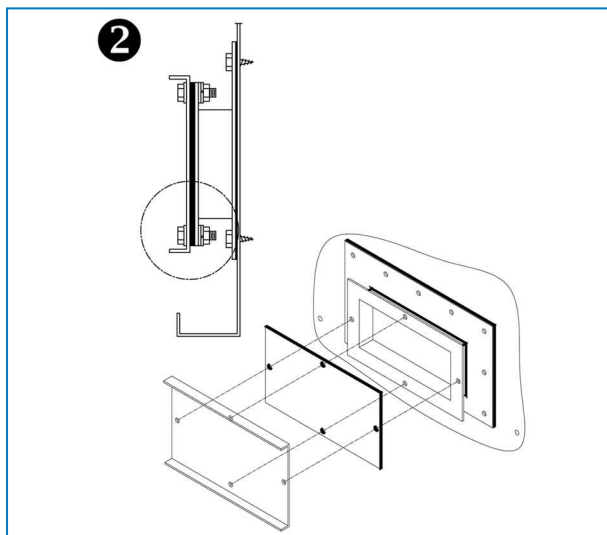

*Final installation of clean out port cover*



S1500E

XES1500E

## INSPECTION PRIOR TO START-UP

### General

Prior to start-up, the following services, which are described in detail in the Operating and Maintenance Manual (see table "Recommended maintenance and monitoring programme" ) must be performed.

Proper start-up procedures and scheduled periodic maintenance will prolong the life of the equipment and ensure trouble-free performance for which the unit is designed.



S1500E

XES1500E

## FURTHER ASSISTANCE & INFORMATION

### The service expert for BAC equipment

We offer tailored services and solution for BAC cooling towers and equipment.

- Original spare parts and fill -for an efficient, safe and year round reliable operation.
- Service solutions - preventive maintenance, repairs, refurbishments, cleaning and disinfection for reliable trouble-free operation.
- Upgrades and new technologies - save up energy and improve maintenance by upgrading your system.
- Water treatment solutions - equipment for controlling corrosion scaling and proliferation of bacteria.

For more details, contact your local BAC representative for further information and specific assistance at [www.BACservice.eu](http://www.BACservice.eu)

### More information

#### REFERENCE LITERATURE

- Eurovent 9-5 (6) Recommended Code of Practice to keep your Cooling System efficient and safe. Eurovent/Cecomaf, 2002, 30p.
- Guide des Bonnes Pratiques, Legionella et Tours Aéroréfrigérantes. Ministères de l'Emploi et de la Solidarité, Ministère de l'Economie des Finances et de l'Industrie, Ministère de l'Environnement, Juin 2001, 54p.
- Voorkom Legionellose. Ministerie van de Vlaamse Gemeenschap. December 2002, 77p.
- Legionnaires' Disease. The Control of Legionella Bacteria in Water Systems. Health & Safety Commission. 2000, 62p.
- Hygienische Anforderungen an raumluftechnische Anlagen. VDI 6022.

#### INTERESTING WEBSITES

Baltimore Aircoil Company	<a href="http://www.BaltimoreAircoil.com">www.BaltimoreAircoil.com</a>
BAC Service website	<a href="http://www.BACservice.eu">www.BACservice.eu</a>
Eurovent	<a href="http://www.eurovent-certification.com">www.eurovent-certification.com</a>
European Working Group on Legionella Infections (EWGLI)	<a href="http://EWGLI">EWGLI</a>
ASHRAE	<a href="http://www.ashrae.org">www.ashrae.org</a>
Uniclíma	<a href="http://www.uniclíma.fr">www.uniclíma.fr</a>
Association des Ingénieurs et techniciens en Climatique, Ventilation et Froid	<a href="http://www.aicvf.org">www.aicvf.org</a>
Health and Safety Executive	<a href="http://www.hse.gov.uk">www.hse.gov.uk</a>

#### ORIGINAL DOCUMENTATION



This manual is originally made in English. Translations are provided for your convenience. In the event of discrepancies, the English original text shall prevail over the translation.



A series of horizontal dotted lines for writing, spanning the width of the page.



A series of horizontal dotted lines spanning the width of the page, providing a template for writing or data entry.







A series of horizontal dotted lines for writing, spanning the width of the page.



A series of horizontal dotted lines spanning the width of the page, providing a template for writing or drawing.





A series of horizontal dotted lines for writing, spanning the width of the page.

COOLING TOWERS

---

CLOSED CIRCUIT COOLING TOWERS

---

ICE THERMAL STORAGE

---

EVAPORATIVE CONDENSERS

---

HYBRID PRODUCTS

---

PARTS, EQUIPMENTS & SERVICES

BLUE by nature  
GREEN at heart



[www.BaltimoreAircoil.com](http://www.BaltimoreAircoil.com)

[Europe@BaltimoreAircoil.com](mailto:Europe@BaltimoreAircoil.com)

Please refer to our website for local contact details.

Industriepark - Zone A, B-2220 Heist-op-den-Berg, Belgium

© Baltimore Aircoil International nv